

Definition: all metals reusable slotted self-locking hexagon flange nut with free washer

Threading: series UNC / UNF ANSI B1.1 and BS 1580 - BSF / BSW on request

Characteristic and performance test: for steel ISO 898-2 / ISO 2320
for stainless steel ISO 3506-2 / NFE 25035



d nominal	pitch / UNC	pitch / UNF	s	h	m	d ₂ *	s ₁	codes
N°10	24	32	9,00	8,00	3,00	14,00	1,30	I
1/4	20	28	11,00	9,50	4,00	18,00	1,40	K
5/16	18	24	13,00	10,80	4,80	22,00	1,60	L
3/8	16	24	14,00	10,80	4,80	22,00	1,60	M
7/16	14	20	17,00	13,50	6,00	27,00	1,80	N
1/2	13	20	18,00	15,80	7,20	30,00	2,40	O
5/8	11	18	24,00	21,00	9,50	40,00	3,20	Q
3/4	10	16	28,00	25,00	12,00	40,00	3,20	R

* Different type and diameter of washers can be supplied on request

Quality class	Classification	Range of application
Class 8 steel / Grade 5	QV	Self color -50° C +300° C [Ⓛ]
Class 10 steel / Grade 8	QK	
Class 12 steel / Grade 10	QL	
Stainless steel A2-70	ZE	Corrosive atmosphere -200° C +400° C [Ⓛ]
Stainless steel A4-80	ZH	

[Ⓛ] Values are only given as an indication

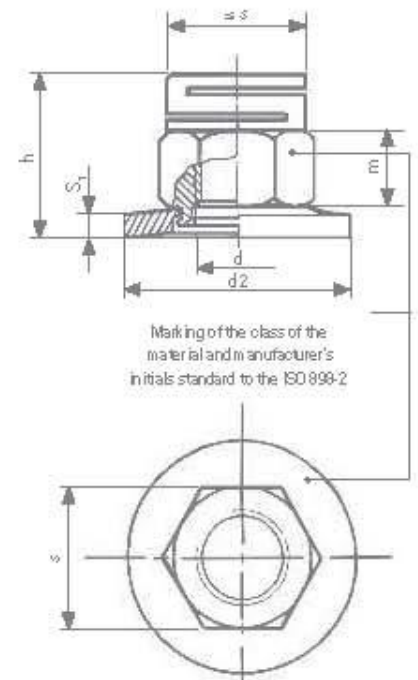

Surface treatment (standard to ROHS requirements)			
Electrolytic coating (steel)	Yellow	ZJ	ISO 4042
	White Lanthane Ⓢ Finish	ZL	400 h
	White Lanthane Ⓢ Finish + Top coat	ZF	600 h
Zinc lamellar (steel)	600 h to 1000 h salt spray		on request
Antigalling (stainless steel)	Stanal Ⓢ400	ST	
	Sherardisation (NF EN 13811)	SH	
Self Color		BT	

Example of ordering code					
	Type	Diam X pitch	Class	Protection	
classification	ERM	N00UNF	QV	ZL	01
	ERM	ø 7/16" UNF	8	Zinc LanthaneⓈ	*

*Standard size